

SAMPLECUT FSC-12

On-line sample cutter

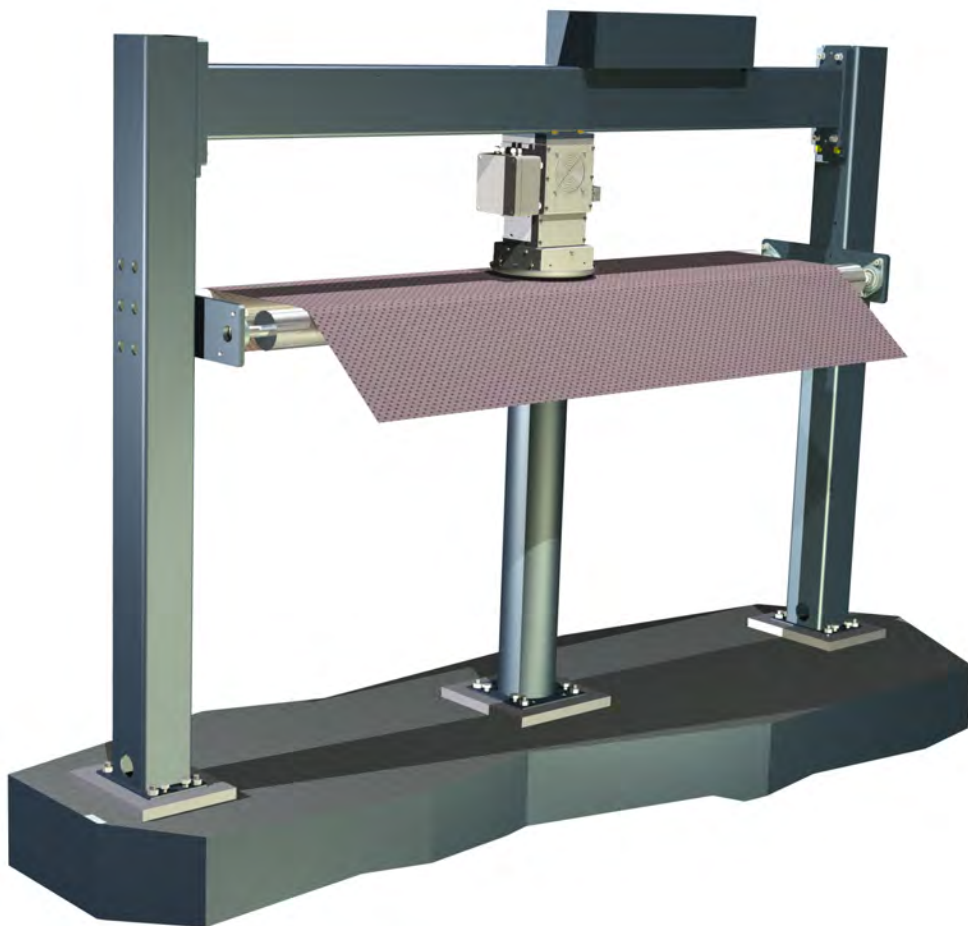

SAMPLECUT FSC-12



Quality made
in Germany



TEXTILE



NONWOVEN



COATING &
CONVERTING



PAPER



EXTRUSION

SAMPLECUT FSC-12

Area of application



Sample cutting online – without having to stop the machine



Customer benefits

- ✓ Takes samples from online materials
- ✓ No downtimes as a result of sampling
- ✓ Simplicity itself to operate
- ✓ Increases productivity
- ✓ Ensures a more efficient use of processing machinery

To monitor the progress of certain processes there is no alternative but to take frequent samples at the machine itself. However, this can only be done whilst the material is at a standstill or running slowly, and often leads to all manner of ambitious, sometimes absurd measures to enable the process to run continuously (non-stop batching, etc.).

Principle of operation

With the Samplecut FSC, Mahlo offers a solution to the problem. The Samplecut FSC can be installed for example at a convenient place at the delivery end of a stenter. The pneumatics work at high pressure and press the circular blade through the material and against a counter block, all in a fraction of a second. The sample is punched out and fed via the sampling device to the operator end.

Equipment



Product highlights

- ✓ Sampling at maximum line-speeds
- ✓ Punching in fractions of a second
- ✓ Increases the efficiency of production machinery
- ✓ Robust, simple construction

The tried and tested Samplecut FSC appliance cuts samples from the high-speed product, and comprises in essence:

- Circular blade
 - Ø: 112,8 mm; A: 100 cm²
 - Ø: 159,6 mm; A: 200 cm²
- Pneumatic unit
- Sample chute
- Control panel
- Switch panel

Control element

The operator need only press a button to release the sample via the control panel.

TECHNICAL DATA

Angabe	Wert	Einheit
Measuring principle	Fixed sample cutter	
Size Samples	100 200	cm ²
Power supply	230 / 400	VAC
Line frequency	50 / 60	Hz
Power supply	5 - 45	°C

Dimensions

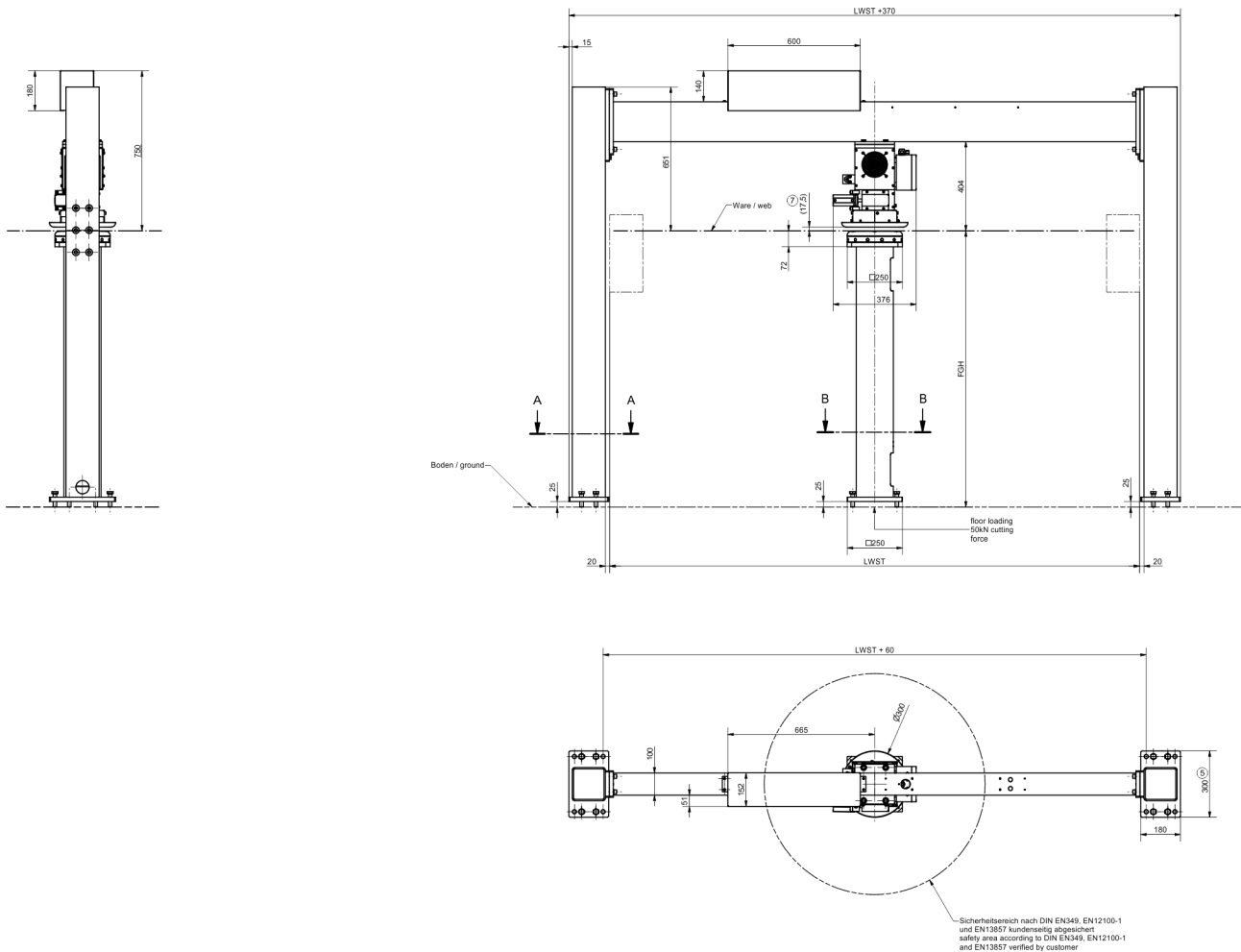

Samplecut FSC-12 (91-014654-006)

Monitoring and control systems, automation:

MAHLO ENSURES QUALITY. WORLDWIDE, IN YOUR VICINITY.

Best-possible technical support and know-how transfer are written in capital letters at Mahlo. Thanks to an international network of agencies and service centres, customers have at their disposal competent support worldwide. We are there for you 365 days a year, 24 hours a day. Just get in touch with us!

- ✓ Over 40 service centres worldwide
- ✓ Service partners in over 100 countries
- ✓ Direct service and spare parts delivery within 24 hours
- ✓ Remote diagnostic system
- ✓ Service hotline: +49-180-5062456



Mahlo GmbH + Co. KG - Germany

Donastr. 12
93342 Saal / Donau
Telephone: +49-9441-601-0
Fax: +49-9441-601-102
Email: info@mahlo.com

Mahlo Italia S.R.L. - Italy

Via Fiume 62
21020 Daverio
Telephone: +39-0332-94-95-58
Fax: +39-0332-94-85-86
Email: mahlo.italia@mahlo.com

Mahlo America Inc. - USA

575 Simuel Road
Spartanburg S.C. 29304
Telephone: +1-864-576-62-88
Fax: +1-864-576-00-09
Email: mahlo.america@mahlo.com

Mahlo Ouest S.P.R.L. - Belgium

Quantum Center
Hütte 79 - Bte 10
4700 Eupen
Telephone: +32-87-59-69-00
Fax: +32-87-59-69-09
Email: mahlo.ouest@mahlo.com

Mahlo España S.L. - Spain

Calle Luxemburgo nº 4
08303 Mataró (Barcelona)
Telephone: +34-938-640-549
Email: mahlo.espana@mahlo.com

WWW.MAHLO.COM

Samplecut FSC-12 84-010298, 1, en_GB

06/2018 Subject to revision!

© 2018 Mahlo GmbH + Co. KG

